

Dresser* Pipeline Solutions Meter Sets and Service Valves for Gas Distribution Piping Systems

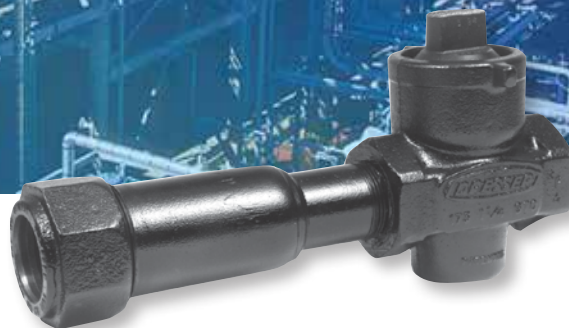

Table of Contents

Introduction.....	Page 3
Style 175 GTO Gas Service Valve	Page 4
Style 175 Meter/Curb Valve	Page 5
Style 175 "Cut-In" Valve	Page 6
Style 275 Gas Meter Valve	Page 7
Style 350 Ultraseal™ Flange End Valve	Page 8
Style 350 Ultraseal™ Weld End Valve	Page 9
Style 575 Angle Ball Valve.....	Page 10
Valve Accessories and Other Products.....	Page 11



GE's Dresser* Pipeline Solutions

Serving the natural gas and oil energy markets

Millions of GE's Dresser couplings, fittings, service connectors, repair sleeves, valves, meters, meter sets and much more have been installed on gas piping systems throughout the world.

Dedicated Sales and Service Support

Underscoring GE's commitment to the marketplace is an unparalleled network of gas market direct field sales representatives who work with our customers "one-on-one" in helping to find optimum solutions to their most critical piping application problems. They are backed by a group of informed and knowledgeable inside customer service specialists ready to assist customers in product selection, system design and installation techniques.

The GE plant in Bradford contains nearly 500,000 square feet for the designing, manufacturing and testing of piping products for the natural gas and other markets.

Recent equipment upgrades include the incorporation of robotics, as well as high speed, automated machining, welding and material handling equipment focused at improving overall efficiencies and response time to customer demands.



From Model to Metal

Using 3-D modeling and analysis software GE's Product Development Teams are able to design new products and product upgrades more efficiently. With finite element software, the 3-D model can be used to determine if the product part will meet the needed size and fitting requirements prior to fabrication.

With this modeling software, not only is it possible to evaluate individual parts or components fully assembled in the computer, but physical testing is simulated on the 3-D model and eliminated on the prototype. This assembly can then be checked for component interference/clearance or misalignment. Using animation software, the assembly and disassembly of components can be evaluated then fully rendered for realistic images allowing visualization of the final product.

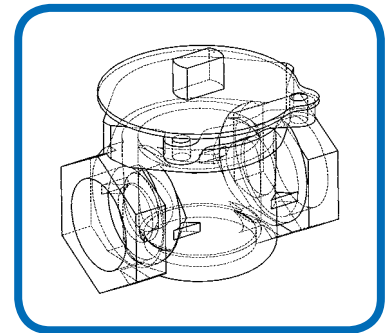

Universal Valve Testers

The GE facility has installed four universal valve testers that provide a totally automated, computerized method of testing both metallic and plastic valves to all ANSI and D.O.T. standards. Not only does this system enhance the overall quality of our valve product line, it also automatically date stamps the accepted valves for lot traceability, per ISO 900:2009 standards.

Style 175 GTO Threaded Gas Valve FIPS x FIPS

Gas-tight, Maintenance-free, and Permanently Lubricated

- Permanently lubricated at the factory for maintenance-free service
- Low operating torque - No plug “freezing”
- 00% shut-off; 360° turn or 90° Open Left operation
- Features a superior tamper-proof design
- No leakage to the atmosphere
- One valve covers full pressure range

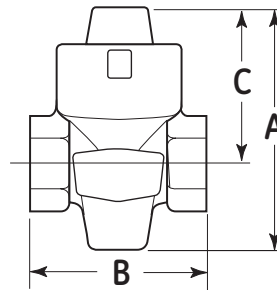

Designed to meet the requirements of ANSI B16.33 1981, the Dresser Style 175 GTO gas service valve incorporates the same complementary sealing principles as the Style 175 meter curb valve, yet offers a rated working pressure to 175 psig. Each GTO valve is 100% factory-tested at high and low pressure while in a clear non-corrosive fluid.

Just as the Style 175 meter curb valve, the GTO is assembled at the factory and sealed against tampering by a spring loaded stainless steel retaining ring which cannot be removed with ordinary tools. It is tamper proof as specified in D.O.T. 192.363 Part C.

A plastic ring inserted between the retaining ring and bonnet, plus permanently lubricated port seals, assure low, uniform operating torque, preventing the plug from freezing to the body.

Style 175 GTO Size Specifications

Nom Size	A	B	C
3/4"	4-13/16"	3"	3-1/16"
1"	5-5/16"	3-5/8"	3-17/32"
1-1/4"	5-3/16"	4-9/16"	3-7/8"
1-1/2"	6-7/16"	5-5/32"	4-7/32"
2"	6-15/16"	5-23/32"	4-1/2"

	Material
Body and Bonnet	Cast Gray Iron - ASTM A126 Class B (Semi Steel)
Plugs	3/4", 1", 1-1/4" and 1/2" Aluminum Alloy
2" Plug	Cast Gray Iron - ASTM A126 Class B (Semi Steel)
Elastomer Seal	Molded, Permanently Lubricated
Elastomer Seal Inserts	Elastomer, Bonded to C-1018 Steel Plate
Retainer Ring	Type 304 Stainless Steel
Plastic Friction Ring	Polypropylene
Bonnet Seal O-ring	Buna S for gas service applications
Spring	Oil-tempered steel to ASTM A-229 specifications

Style 175 Meter/Curb Valve Compression x Compression

With Universal 90 Compression Ends for Steel x Steel, Steel x P.E. and P.E. x P.E. Seal & Restraining Connections

- Permanently lubricated at the factory for maintenance-free service
- Low operating torque - No plug “freezing”
- 100% shut-off; 360° turn or 90° Open Left operation
- Features a superior tamper-proof design
- No leakage to the atmosphere
- One valve covers full pressure range

The design of the Dresser Style 175 gas service valve utilizes two complementary sealing principles which work together to assure positive shut-off at all rated working pressures to 150 psig. The oil-tempered steel spring exerts a constant force on the tapered plug and seal inserts, providing a seal against low line pressure. At higher pressures, this spring load is supplemented through a unique design which employs line pressure to exert an additional positive sealing force. As line pressure is increased, greater sealing force on the elastomeric seals is produced causing the valve to remain gas tight at all working pressures within its recommended working range.

Tamper-Proof per DOT Specs

The Style 175 valve is assembled at the factory and sealed against tampering by a spring loaded stainless steel retaining ring which cannot be removed with ordinary tools. It is tamper proof as specified in D.O.T. 192.363 Part C.

Low Operating Torque

A plastic ring inserted between the retaining ring and bonnet, plus permanently lubricated port seals, assure low, uniform operating torque, preventing the plug from freezing to the body.

100% Factory Tested

Each valved is tested at high and low pressure while in a clear non-corrosive fluid.

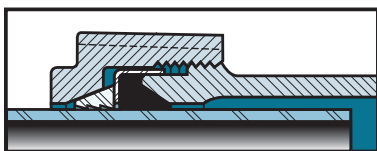

Compression-ends of the '175' valve employ the Dresser Universal 90 seal & restraint design to create a positive pipe restraint on both pipe ends.

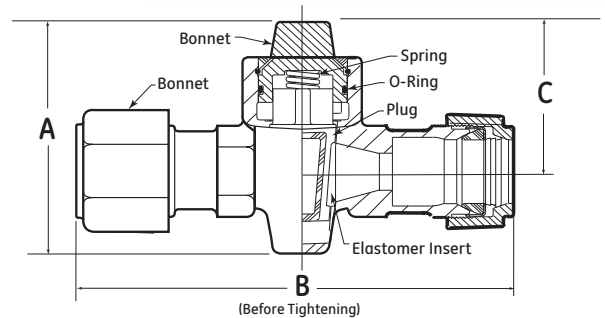

Style 175 Meter Valve with Universal 90 Ends						
Pipe	Nom Size (I.D. in)	Outside Diameter (O.D. in)	SDR	A	B	C
Steel x Steel	3/4	1.050	—	5	8-3/4	3-1/16
	1	1.315	—	5	9-1/2	3-7/8
	1-1/4	1.660	—	6	9-3/4	3-7/8
	1-1/2	1.900	—	6	10-1/2	4-7/32
	2	2.375	—	7	10-1/4	4-1/2
Steel x P.E. and P.E. x P.E.	3/4	1.050	11	5	8-3/4	3-1/16
	1	1.315	9.3	5	9-1/2	3-7/8
	1	1.315	11	5	9-1/2	3-7/8
	1-1/4	1.660	9.3	5	9-3/4	3-7/8
	1-1/4	1.660	10	6	9-3/4	3-7/8
	1-1/4	1.660	11	6	9-3/4	3-7/8
	1-1/2	1.900	11	6	10-1/2	4-7/32
	2	2.375	9.3	7	10-3/4	4-1/2
	2	2.375	9.3	7	10-3/4	4-1/2

Material Specifications	
Body and Bonnet	Cast Gray Iron - ASTM A126 Class B (Semi Steel)
Plugs	3/4", 1", 1-1/4" and 1/2" Aluminum Alloy
2" Plug	Cast Gray Iron - ASTM A126 Class B (Semi Steel)
Elastomer Seal	Molded, Permanently Lubricated
Elastomer Seal Inserts	Elastomer, Bonded to C-1018 Steel Plate
Retainer Ring	Type 304 Stainless Steel
Plastic Friction Ring	Polypropylene
Bonnet Seal O-ring	Buna S for gas service applications
Spring	Oil-tempered steel to ASTM A-229 specifications

Style 175 M “Cut-In” Curb Valve

Available with FIPS x Compression and Universal 90 x 90 Compression Ends for Steel and P. E. Connections

The Dresser Style 175 Cut-In Valve permits easy replacement of existing threaded or compression end curb valves as well as installation in service lines without curb valves. Utilizing the same sealing principle as the other ‘175’ valves, the “Cut-In” 175 provides top performance from inches of water column to 175 psi.

The “Cut-In” valve is available with Universal 90 Compression x Compression or FIPS x Compression ends, and is thoroughly tested at high and low pressure prior to shipment.

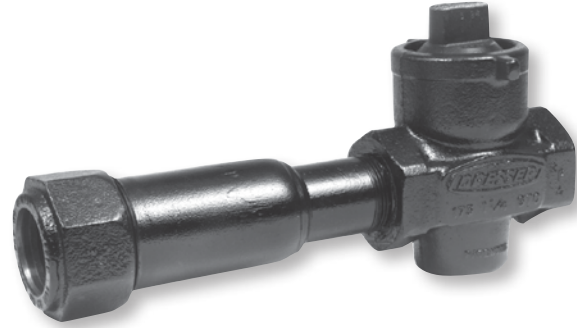

Style 175 “Cut-In” Curb Valve Specifications (with FIPS X Universal 90 Compression End)

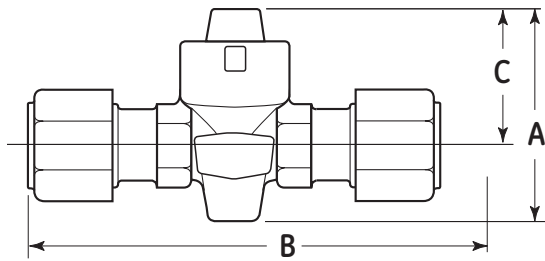

FIPS x Compression End Configuration		
Nom. Size (in)	A Length	B Cut-in Adapter Depth (in)
3/4	10-1/2	5
1	11-1/8	5
1-1/4	12-3/8	5
1-1/2	12-3/4	5
2	13-1/4	5

Style 175 “Cut-In” Curb Valve Specifications (with Universal 90 x 90 Compression End)

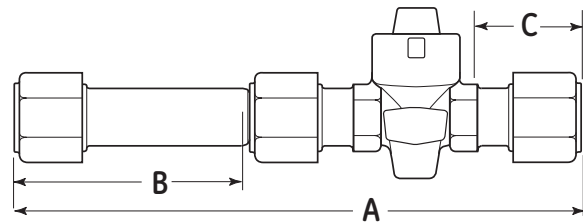

Compression x Compression End Configuration			
Nom. Size (in)	A Length	B Cut-in Adapter Depth (in)	C Pipe Entrance Depth (in)
3/4	14-1/4	5	2-1/1
1	14-1/2	5	2-3/4
1-1/4	14-3/4	5	2-3/4
1-1/2	15-1/4	5	2-3/4
2	15-3/4	5	2-3/4

Material Specifications

Body and Bonnet	Cast Gray Iron - ASTM A126 Class B (Semi Steel)
Plugs	3/4", 1", 1-1/4" and 1/2" Aluminum Alloy
2" Plug	Cast Gray Iron - ASTM A126 Class B (Semi Steel)
Elastomer Seal Inserts	Elastomer, Bonded to C-1018 Steel Plate
Retainer Ring	Type 304 Stainless Steel
Plastic Friction Ring	Polypropylene
Bonnet Seal O-Ring	Buna S for gas service applications
Spring	Oil-tempered steel to ASTM A-229 specifications

Style 275

A compact, economical gas meter valve

- Permanently lubricated at the factory for maintenance-free service.
- Valve body and plug are high grade malleable or ductile iron.
- Features a superior tamper-proof design.
- Valve stem is dual O-ring sealed. One O-ring provides a positive pressure seal to the atmosphere, the other seals against moisture intruding between the body and bonnet.
- Bottom of valve body is solid...Eliminates any leak path to the atmosphere.
- Lock-wing is an integral part of the plug.
- Each valve body features a boss to accommodate a 1/8" IPS tap for testing.
- Meets all requirements of ANSI B 16.33-81 and conforms to D.O.T. 192.

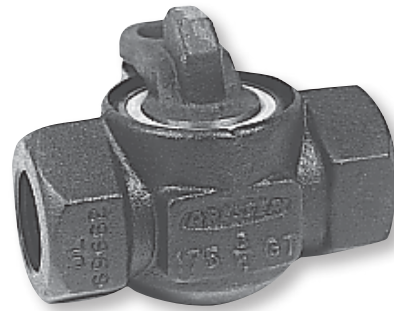

The Dresser Style 275 gas meter valve is a maintenance-free, compact and reliable positive shut-off valve. Rated for operating pressures from inches of water column to 175 psig, the Style 275 is available in sizes 3/4", 1" and 1-1/4", in regular FIPS, lock-wing FIPS, insulated union, and insulated union lock-wing configurations. A 3/4" x 1/2" size in all type configurations is also available.

Operating Principle

The Style 275 incorporates a spring loaded seat, plus a self-sealing feature which increases sealability as operating pressure increases. At low pressures, the leaf-type springs exert pressure to force the elastomeric-coated insert seals into a positive sealing position.

At higher pressures, the valve is designed to employ the gas line pressure to impose a supplemental compressive loading against the seals. The higher the line pressure, the greater the sealing force. Since this force can be exerted on either seal, the valve is non-directional.

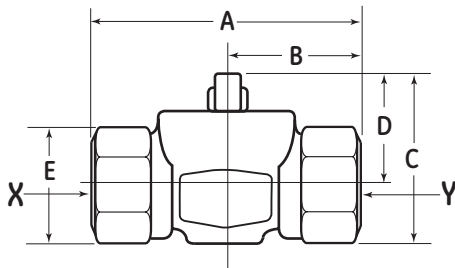

Style 275 Meter Valve Specifications

Size X & Y (in)	A (in)	B (in)	C (in)	D (in)	E (in)
3/4 x 1/2	3-3/8	23/32	2-17/32	1-5/8	1-7/8
3/4	3-3/8	23/32	2-17/32	1-5/8	1-7/8
1	3-7/8	3/4	2-29/32	1-13/16	2-1/8
1-1/4	4-1/4	13/16	3-11/32	2-1/32	2-7/16

Standard Coating

The Style 275 is supplied with a zinc phosphate finish as standard which can be utilized as either the prime coat or as the sole coating, depending on service conditions. Salt-spray tests have shown zinc phosphate to provide excellent corrosion resistance. Plus, most top coats readily adhere to zinc phosphate.

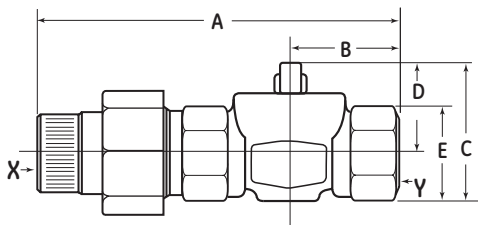

Style 275 Meter Valve Specifications with Insulated Union End

Size X & Y (in)	A (in)	B (in)	C (in)	D (in)	E (in)
3/4	5-25/32	23/32	2-17/32	1-5/8	1-7/8
1	6-5/8	3/4	2-29/32	1-13/16	2-1/8
1-1/4	7	13/16	3-11/32	2-1/32	2-7/16

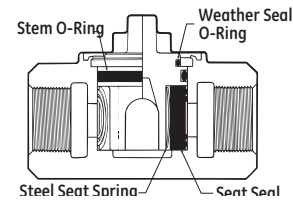
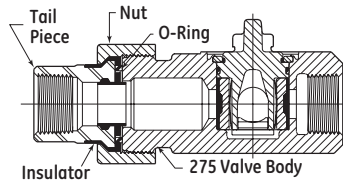

Material Specifications

Body and Stem Bonnet	High grade malleable or ductile iron
Weather Seal O-ring	Buna N Rubber
Stem Seal O-ring	Buna S Rubber
Retaining Seats	Buna N Rubber
Retaining Seat Pads	Ferrous Powder Metal
Retainer Seat Spring	Type 304 Stainless Steel

Style 350 Ultraseal Flanged End Gas Valves

Style 350 flange-end valves are ideal for use in Dresser fabricated meter sets

Style 350 valves provide bidirectional, bubble-tight shut-off and zero leakage to the atmosphere

- Permanently lubricated: Saves the time and hassle of re-lubrication. Designed to prevent freeze-up or blocking of meters with lubricant.
- Bi-directional: No worries about whether the valve was installed in the proper direction.
- Bubble-tight seal: After qualification testing to over 10,000 cycles, the valve sealed bubble-tight at -30°F under both low and high pressure.
- Sizes and operating pressure: Available in 1-1/4", 1-1/2", 2", 3" and 4" valve sizes with operating pressures from inches of water column to 175 psig.
- Temperature ratings: -20° F. to 150° F.
- High flow capacity: Open position provides optimum flow capacity. Meets applicable sections of ANSI B16.33 or B16.38.
- 100% Tested: Each valve is extensively tested to ANSI B16.33 or B16.38 requirements prior to shipping.
- Torque values: Extremely low operating torque even at subzero temperature. Meets ANSI B16.33.
- Ribbed design: Provides excellent valve performance, even with piping loads on the valve.
- Locking plate: Standard locking plate is available for lock-on/lock-off applications.
- Body and Plug construction: Valves are ruggedly constructed of ductile iron with top entry to simplify future repair, if required.
- Epoxy-coated as standard for excellent corrosion protection.
- Specially designed for high performance rotary meters and other precision measurement and flow regulation equipment utilized in the natural gas industry.
- 2" Square operating nut is optional

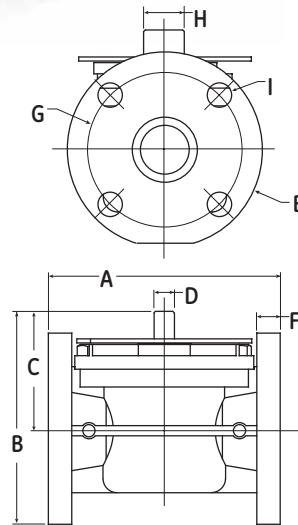
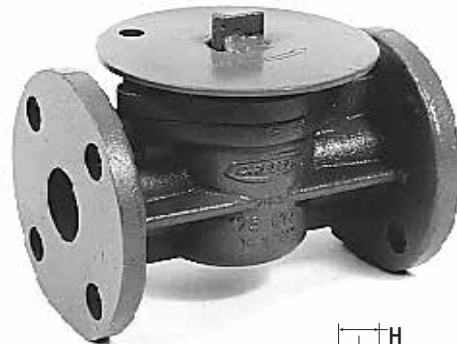

Material Specifications

Body and Top Plate	Ductile Iron, ASTM A536 GR 65-45-12
Plug	Ductile Iron, ASTM A536 GR 65-45-12
O-ring Seals	SBR - Especially compounded for long life in natural gas service
Metallic Atmospheric Seal	18-8 Stainless Steel
Springs	Stainless Spring Steel
Cap Screws	Steel, ASTM A193 Grade B5
Torque Ring	Polyurethane
Port Seals	SBR rubber molded over high tensile strength steel
Weather Seal	Chloroprene Rubber
Lock Plate	Carbon Steel

Style 350 Ultraseal Flanged Valve Specifications

Size (in)	Length A (in)	Height B (in)	Center C (in)	D (in)	E (in)	F (in)	G (in)	H (in)	I (in)	Bolt Holes
2	7	6-9/16	3-11/16	5/8	6	5/8	4-3/4	1-1/4	3/4	4
3	8	8-15/16	5-3/8	3/4	7-1/2	3/4	6	1-1/2	3/4	4
4	9	10-1/2	6	1	9	15/16	7-1/2	2	3/4	8

Style 350 Ultraseal Weld End Gas Valves

Style 350 weld end valves are ideal for use in welded meter sets, regulator stations for pipeline isolation applications

- Permanently lubricated: Saves the time and hassle of re-lubrication.
- Designed to prevent freeze-up or blocking of meters with lubricant.
- Bi-directional: No worries about whether the valve was installed in the proper direction.
- Temperature Ratings: -20° F. to 150° F.
- Flow capacity: Flow capacity requirements meet applicable sections of ANSI B16.33 or B16.38.
- Ribbed design: Provide excellent valve performance even with piping loads on valve.
- Torque values: Extremely low operating torque even at subzero temperature.
- Locking plate: Standard locking plate is available for lock-on/lock-off applications.
- Coating: Epoxy-coated for excellent corrosion protection.
- Sizes and operating pressure: Available in 2" valve size with operating pressures from inches of water column to 175 psig.
- Specially designed for high performance rotary meters and other precision measurement and flow regulation equipment utilized in the gas industry.
- 2" square operating nut is optional.

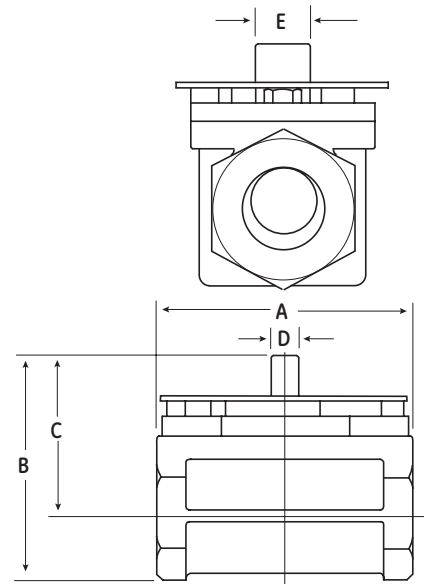
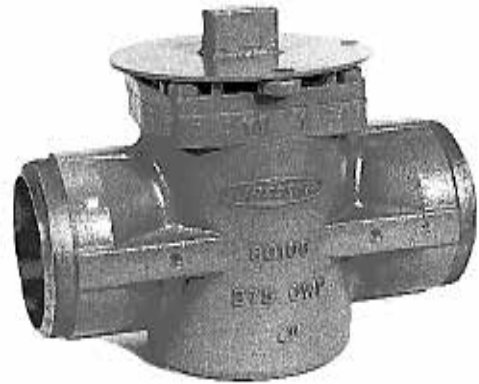

Style 350 Ultraseal Weld End Valve Specifications					
Size (in)	Length A (in)	Height B (in)	Center to Top C (in)	D (in)	E (in)
2	8-1/2	5-9/16	3-11/16	5/8	1-1/4

Material Specifications	
Body & Top Plate	Ductile Iron, ASTM A536 FT 65-45-12
Plug	Ductile Iron, ASTM A536 FT 65-45-12
O-ring Seals	SBR - Especially compounded for long life in natural gas service
Metallic Atmospheric Seal	18-8 Stainless Steel
Springs	Stainless Spring Steel
Cap Screws	Steel, ASTM A193 Grade B5
Torque Ring	Polyurethane
Port Seals	SBR Rubber Molded over High Tensile Strength Steel
Weather Seal	Chloroprene Rubber
Lock Plate	Carbon Steel

Style 575 Angle Ball Valve

Offers a service tee connection, plus a shut-off valve...All in one!

The Dresser Style 575 Angle Ball Valve provides dual service as a main-to-service compression end tee connection, and as a shut-off valve.

Constructed of a unique combination of a rugged ductile iron body and a high-strength engineered plastic plug, the 575 valve offers a low torque 90-degree operation with positive, bottle-tight shut-off at pressures up to 125 psi. Designed for durability under all service conditions, the interface of ductile and engineered plastic components eliminates any possibility of valve freeze-up due to corrosion.

The 575 also eliminates the presence of an isolated metallic valve in a plastic service. The ductile material in the valve body is compatible with the cast iron main, so there's no need for anoding and monitoring. Plus, an optional Dresser Plastisol™ coating can provide even greater external corrosion protection.

The compression end for connecting the service is of a time-proven Dresser design and meets all the requirements of D.O.T. 192.283(b), providing a permanent seal and pull-out resistance greater than the P.E. tubing in tension.

The 575 is available in inlet sizes 1-1/4" or 1-1/2" MIPT and an outlet size of 1-1/8" OD, but it can be readily adapted to other outlet sizes as required.

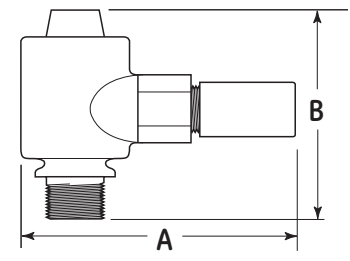
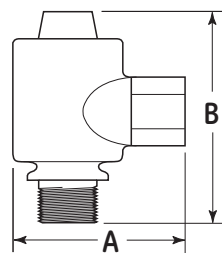
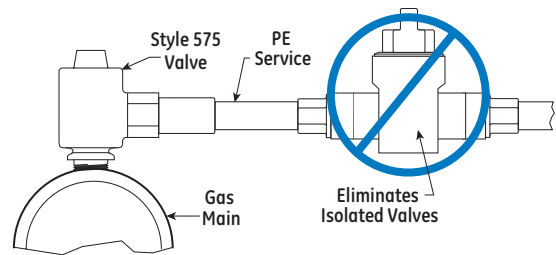

Style 575 Valve with Shield Nut

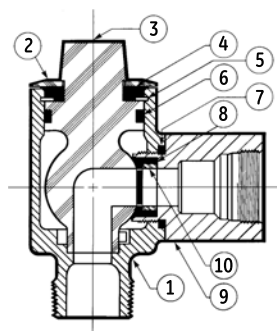

Item	Description
1	Body
2	Bonnet Cap
3	Valve Plug
4	Moisture Seal
5	Retainer Ring
6	O-ring
7	Branch Gasket
8	Seat Gasket
9	Valve Branch
10	Gasket Retainer

Material Specifications

Body and Top Plate	Ductile Iron, ASTM A536 GR 65-45-12
Plug	Ductile Iron, ASTM A536 GR 65-45-12
O-ring Seals	SBR - Especially compounded for long life in natural gas service
Metallic Atmospheric Seal	18-8 Stainless Steel
Springs	Stainless Spring Steel
Cap Screws	Steel, ASTM A193 Grade B5
Torque Ring	Polyurethane
Port Seals	SBR rubber molded over high tensile strength steel
Weather Seal	Chloroprene Rubber
Lock Plate	Carbon Steel

Style 575 Angle Ball Valve Specifications

Pipe Size Inlet x Branch (in)	Tubing Wall Thickness (in)	A Length 501 End (in)	A Length w/Shd Nut (in)	B Overall Height (in)
1-1/4 MIPT x 1-1/8 OD	.090	5-1/4	5-7/8	4-7/8
1-1/2 MIPT x 1-1/8 OD	.090	5-1/4	5-7/8	4-7/8

Gas Valve Accessories

Insulating Valves

GE's Dresser compression-end type gas service valves can be furnished insulated (one end insulated, the other conductive) to eliminate the need for separate insulating fittings. The principle and construction of the insulating valves are the same as for the regular Style 90 insulating couplings and fittings.



2" Square Operating Nut Adapter

This cap provides a convenient means for adapting underground valves to a square nut top while protecting the valve against dirt accumulation. The cap also provides a 90° turn feature. Available in either open right or open left configuration.



Style 2175 Locking Bar

Designed for the Dresser Style 175 Meter Curb Valve, the Style 2175 Locking Bar is available in both On and On/Off NPT configurations from 3/4" through 2" Sizes. See chart below for sizes.

Size (in)	Description	Configuration
3/4	1.050 Locking Bar	Off NPT
1	1.315 Locking Bar	Off NPT
1	1.315 Locking Bar	On NPT
1	1.315 Locking Bar	Off Comp
1-1/4	1.660 Locking Bar	Off NPT
1-1/4	1.660 Locking Bar	On NPT
1-1/2	1.900 Locking Bar	Off NPT
2	2.375 Locking Bar	Off NPT 1/2 Dia LKC
2	2.375 Locking Bar	On/Off NPT



Técnica Hansa - Marchant Pereira 540 Providencia
Santiago, Chile. Teléfono: (+56 2) 2204 5348

GE Oil & Gas

41 Fisher Avenue,
Bradford, PA 16701, U.S.A.

T: +1 814.362.9200
F: +1 814.362.9344

Visit us online at: www.ge.com/energy

2014 General Electric Company
All Rights Reserved

*Trademark of General Electric Company

GEA31554A

12/2014