

# Product Selection & Application Guide

## For Natural Gas Transmission & Distribution Piping Systems

- Pipe Joining - Seal Only or Seal & Restraint
- Pipe Repair Clamps
- Repair & Reinforcing Sleeves
- Service Connectors
- Valves & Strainers
- Excess Flow Valves
- Meter Change-Out Kits
- Prefabricated Meter Sets & Gate Stations
- BLACKHAWK Hot Tap & LineStop Fittings

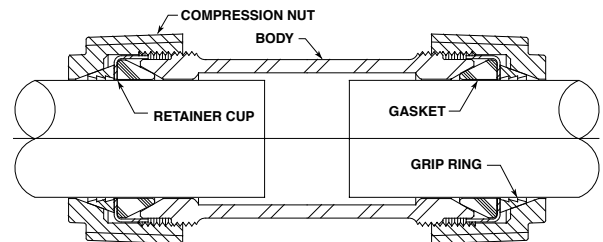

**Gas Market Products**

[www.dresser.com](http://www.dresser.com)

**DRESSER®** has been a leader in the development and manufacture of pipe joining and pipe repair products for over a century. Since the first Dresser coupling patent was granted in 1886, many improvements in design, and advances in pipe joining technology have been achieved.

This manual is recommended as a guide for specifying Dresser piping products on gas & oil distribution piping systems. Dresser pipe joining products are categorized to accommodate two most common conditions: (1) to provide only a seal at the pipe joint, or (2) provide both sealing and restraint against pipe pullout. The Federal Department of Transportation's Code Part 192 addresses the issue of pipe end restraint of piping systems and has established performance requirements specifically related to seal only and restraining-type mechanical joints. (Ref. Paragraphs 192.273(a) and 192.283(b).) The pipeline engineer determines the required category of pipe joint based on the application for conformance to D.O.T. specs. Dresser product component drawing examples are shown on page 2&3 (seal & restraint) and page 4 (seal only) to illustrate these two categories.

Since traditional mechanical couplings and fittings provide **only a seal** on the pipe end when installed, they may **not provide lock or pipe restraint** and, consequently, they do not prevent the pipe from pulling out of the coupling. Longitudinal pull-out or thrust forces caused by thermal expansion and contraction or by internal or external loads, whether anticipated (e.g., settlement of piping) or unanticipated (e.g., third party damage), must be considered when using mechanical type joints. This is especially true when installing polyethylene pipe, which is known to be effected by thermal expansion and contraction 10 to 15 times the rate of steel pipe.

Also, in situations where pipe movement might occur, it is necessary that the piping be properly anchored when using mechanical couplings and fittings. Failure to take this into consideration has been a major cause of pipe pull-out when non-restraining or non-locking mechanical joints were used.

**Note:** Applicable installation and usage warnings are shown on the back cover to help provide some guidelines for safe and reliable product installation. A complete Gas Products DOT Installation Instruction Manual is available through your regional Dresser Sales Representative, or call 814-362-9200 and ask to speak with Gas Market Customer Service. Also, you can email your request to: [dmdsales@dresser.com](mailto:dmdsales@dresser.com)

## DRESSER® Coupling & Fitting Components

The following is a general listing and function of Dresser product components:

- **Anode Connector** - An optional connection provided for attachments of an anode to the coupling, normally on the body or middle ring.
- **Armor** - A metallic gasket tip providing conductivity between the middle ring and follower as well as protection from attack by severe line content.
- **Bolt and Nut** - Provides means of compressing a bolted coupling, providing seal or seal and restraint, depending on coupling design.
- **Compression Nut** - The component that compresses the gasket and grip ring by tightening on to the body of threaded compression couplings and fittings.
- **Follower** - Ring that retains the gasket and provides a means to compress the gasket and grip ring in bolted products.
- **Follower Insulator** - A high dielectric annular sleeve formed to prevent conductivity between the pipe and coupling on the insulating pipe end.
- **Gasket** - Sealing component which is compressed upon installation, providing a pressure seal. Can be insulating or conductive.
- **Grip Ring** - Holds the pipe against pullout in couplings made for seal and restraint.
- **Insert Stiffener** - A tubular reinforcement sleeve used on all polyethylene pipe ends to prevent pipe collapse.
- **Insulator** - A high dielectric cylindrical sleeve preventing electrical shorting between the pipe and middle ring.
- **Middle Ring or Body** - Pressure containing component that bridges the gap between pipe ends.
- **Pipe End Separator** - A high dielectric ring which prevents shorting from pipe end to pipe end.
- **Retainer Cup** - Component that retains the gasket in a threaded compression fitting.

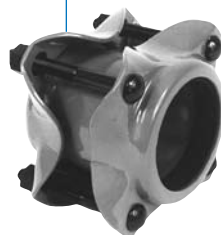

For specific product literature and specification details, please call Dresser Inside Sales at 814-362-9200 and request the complete Gas Market Catalog binder. You can also visit us on the web for an overview of all gas market brochures. [www.dresser.com](http://www.dresser.com)

# DRESSER SEAL & RESTRAINING PPRODUCTS

## Seal & Restraint Couplings & Fittings

### Current Product Line:

- Style 90 Universal Boltless Couplings & Fittings
- Style 401 Couplings & Fittings
- Style 501 Fittings
- Style 700 Universal POSI-HOLD™ Couplings
- Style 711 Couplings & Flange Adapters
- Style 731 Line Caps with Lock Pin
- See Page 6 for Style 175 Valves (w/Universal 90 or 501 Ends); and Style 475 Plastic Curb Valves

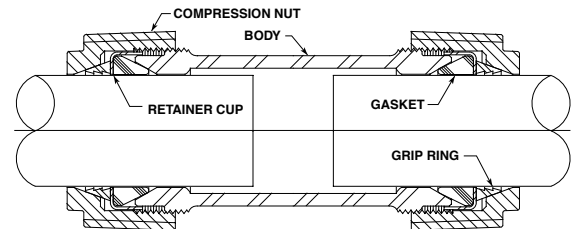

Style 90 Universal Coupling

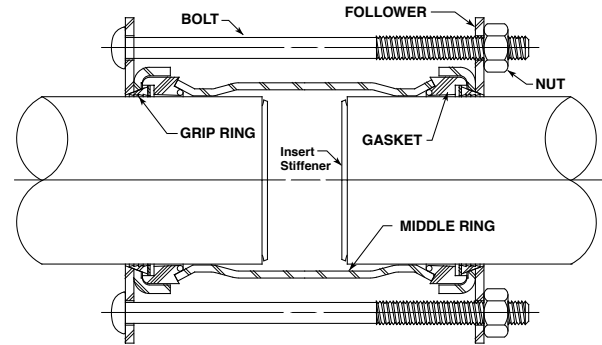







Style 711 Coupling

## PIPE JOINING Seal & Restraint

These products create both a **SEAL** on the pipe and **RESTRAINT** against pipe pull-out.

PIPE	PRODUCT	STYLE NO.	CONFIGURATIONS	SIZES	PSI RATING
P.E. to P.E. P.E. to Copper		Style 401 SEAL-PLUS™ Couplings	Coupling, Ell, Tee, End Cap (Straight & Reducing)	5/8" - 1-3/8"	125 psig
P.E. to Steel		Style 501 Compression End Fitting	Coupling, Adapter, Reducing Coupling	5/8" - 1-3/8"	125 psig
Steel x P.E.		Style 88	Service Head Adapter for Steel x P.E. (Insert Included)	1" - 2"	100 psig
P.E. to P.E. P.E. to Steel Steel to Steel		Universal Style 90 Coupling	Coupling, Ell Tee, Adapter (Straight & Reducing)	3/4" - 2"	150 psig
Steel x Steel Steel x P.E.		Style 90 Universal Service Tee	Tap-N-Valve Tee for IPS Services	3/4" - 1"	150 psig

# PIPE JOINING - Seal & Restraint (cont'd)

PIPE	PRODUCT	STYLE NO.	CONFIGURATIONS	SIZES	PSI RATING
Steel x Steel Steel x P.E.		Style 501 Service Tee	Tap-N-Valve Tee for Steel to CTS Polyethylene	5/8" & 1-1/8"	125 psig
Steel P.E.		Style 64 Bolted Tee	Riser Tee with Insulating and Conductive End Configurations	3" & 4"	150 psig
P.E. to P.E. P.E. to Steel Steel to Steel		Style 700 POSI-HOLD® Hydraulic Couplings	Boltless Coupling, Ell, Tee, Line Cap	3" - 8"	150 psig
P.E. to P.E. P.E. to Steel Steel to Steel		Style 711 Bolted Coupling	Coupling, Flange Adapter, Line Cap, Reducing Coupling (Conductive & Insulating)	1-1/4" - 12"	Varies by size and application
Cast to P.E. Cast to Steel		Style 711 Bolted Coupling	Insulating/Reducing Coupling	3.8" - 13.2"	50 psig
Steel  Cast		Style 731 Bolted Line Cap	Restraining Line Cap with Lock Pin	4" - 12"  4.8" - 13.2"	4 - 6": 150 psig 8 - 12": 60 psig  30 psig

## Seal & Restraint Insulating Products

Dresser insulating product designs are available to electrically isolate sections of piping for cathodically protected systems.

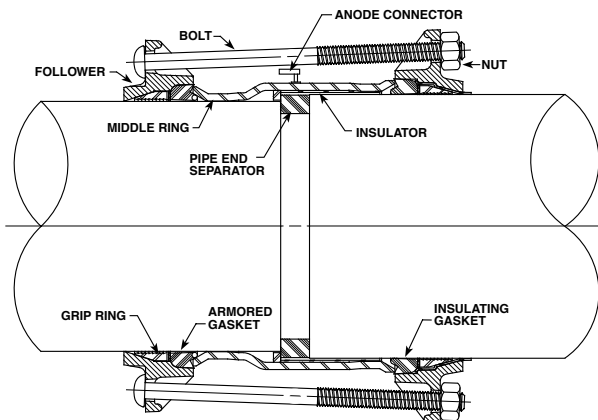

**Style 711 Insulating Coupling**  
Provides Seal AND Pipe Restraint

## Other means of restraining pipe joints:

**Restraining Joint Harnesses:** Used to bridge over a coupling to provide restraint to the joint.

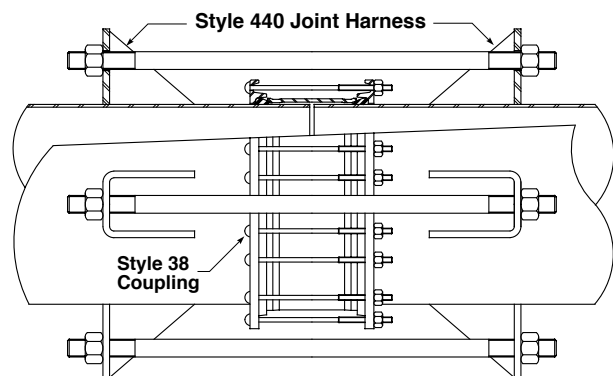

**Style 440 Joint Harness**  
Used in conjunction with a Dresser Style 38  
coupling on steel pipe installations  
(See Product Details Page 10)

# SEAL ONLY and SEAL ONLY INSULATING PRODUCTS

## Seal Only Couplings & Fittings

### Current Product Line:

- Style 38, 39, 40, 39-40 and 39-62 Couplings
- Style 63 Expansion Joints
- Style 60 and 160 Bell Joint Clamps
- Style 128 Flange Adapters
- Style 88 and 90 Fittings
- Style 4, 41, 77, 118 and 360 Repair Clamps
- Style 50, 54, 57, 73, 75, 80, 93, 96, 97, 126 and 850 Sleeves
- See Page 6 for Style 275 and 350 Meter Valves; and Style 351 Valve Strainers

Dresser insulating product designs are available to electrically isolate sections of piping for cathodically protected systems.

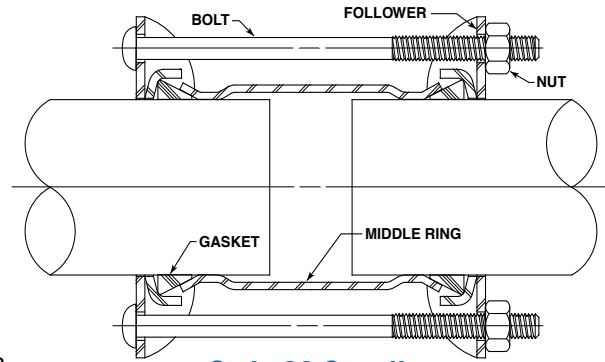

**Style 38 Coupling**  
Provides Seal Only

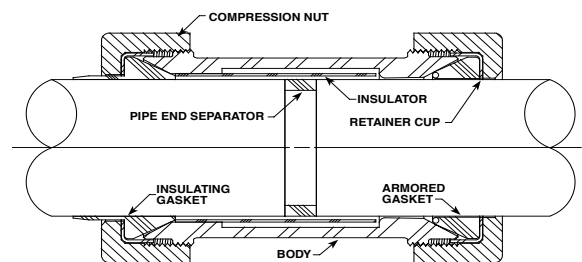





**Style 90 Insulating Coupling**  
Provides Seal Only and Insulating End

## PIPE JOINING

### Seal Only Fittings







These products create SEAL ONLY on the pipe. They do NOT provide restraint against pipe pull-out.

PIPE	PRODUCT	STYLE NO.	CONFIGURATIONS	SIZES	PSI RATING
Copper Tubing		Style 88 Compression Fittings	Brass Coupling, Ell, Male & Female Adapters	1/4" - 1-1/4"	150 psig
Steel x CTS		Style 88	Service Head Adapter for Steel x Copper Tubing (Insert Included)	1" - 2"	150 psig
Steel to Steel		Style 90 Compression Fittings	Coupling, Reducing Coupling, Ell, Tee, Adapter (Conductive & Insulating)	1/2" - 2"	150 psig
Steel x Steel		Style 90 Service tee	Tap-N-Valve Tee for IPS Services (Seal Only)	3/4" - 1"	150 psig











## PIPE JOINING - Seal Only Fittings (cont'd)

PIPE	PRODUCT	STYLE NO.	CONFIGURATIONS	SIZES	PSI RATING
Steel or Cast		Style 91 Saddle	Service Saddle for Steel or CI Pipe (Conductive or Insulating)	2" - 12"	150 psig

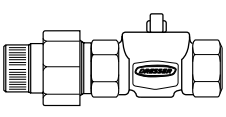





## PIPE JOINING - Seal Only Bolted Couplings

PIPE	PRODUCT	STYLE NO.	CONFIGURATIONS	SIZES	PSI RATING
Steel to Steel Cast to Cast		Style 38	Coupling	1/2" - 24" (and larger)	Varies by size and application
Steel to Steel		Style 39	Insulating Coupling	3/4" - 24" (and larger)	Varies by size and application
Steel to Steel		Style 39-40	Insulating Long Body Coupling	1" - 16"	Varies by size and application
Steel to Steel		Style 40	Long Body Coupling	1/2" - 24" (and larger)	Varies by size and application
Steel to Cast Iron		Style 39-62	Insulating Reducing Coupling	2" - 24" (and larger)	150 psig
Steel Cast Iron		Style 31	Line Cap	2" - 24" (and larger)	150 psig
Steel		Style 128	Flange Adapter	2" - 24" (and larger)	150 psig
Steel to Steel		Style 63	Expansion Joint	Made To Order	150 psig



# VALVES & STRAINERS

PIPE	PRODUCT	STYLE NO.	CONFIGURATIONS	SIZES	PSI RATING
IPS Steel or P.E.		Style 175 x Universal 90	Compression Meter Curb Valve <b>(Seal &amp; Restraint Product)</b>	3/4" - 2"	150 psig
IPS Steel or P.E.		Style 175 x Universal 90	"Cut-In" Curb Valve <b>(Seal &amp; Restraint Product)</b>	3/4" - 2"	150 psig
IPS Steel		Style 175	Compression or Threaded Meter Curb Valve <b>(Seal Only Product)</b>	3/4" - 2"	175 psig
Steel	  Style 275      275 w/ Union End		Threaded Meter Valve or with Insulated Union on one end	3/4" - 1-1/4"	175 psig
Steel		Style 350 "Ultraseal"	Flanged, Threaded or Weld Meter Valve w/Lock Plate	1-1/4" - 4" Flngd. 1-1/4", 1-1/2", 2" Threaded 2" Weld	175 psig 175 psig 275 psig
Pipeline Strainer		Style 351 Pipeline Strainer	Tee Strainer for meters and regulation equipment	Threaded: 1-1/4", 1-1/2", 2" Flanged: 1-1/4", 1-1/2", 2", 3", 4" Weld: 2"	Threaded & Flanged 175 psig; Weld 275 psig
Gasket Strainers		Style 351 Gasket	Flange Gasket Strainer for pipeline and meter set measurement equipment	1" - 6" 20 Mesh	175 psig
P. E.		Style 475 Valve	Plastic Compression Curb Valve <b>(Seal &amp; Restraint Product)</b>	5/8", 1", 1-3/8"	125 psig
Cast/ Ductile X P.E.		Style 575	Compression End Tee	1-1/4" - 1-1/2"	125 psig
Steel & PE Applications		Style 480, 481 & 488 EFV's	Excess Flow Valves-Available in a variety of mechanical and fusion carrier fittings	1/2", 3/4", 1" CTS and IPS New 1/2" CTS Ultra-Low	5-1,000 psig

# REPAIR CLAMPS

PIPE	PRODUCT	STYLE NO.	CONFIGURATIONS	SIZES	PSI RATING
Steel		Style 4/41	Collar Leak Clamp	3/4" - 12"	1000 psig
Steel		Style 75	High Pressure "Permaclamp"	4" - 8" 10" - 36"	1200 psig  Varies by size and applicaton
Steel		Style 77	Band Clamp (w/cone shaped gasket)	2" - 12"	150 psig
Steel		Style 118 "Handiband"	Band Clamp	1/2" - 3" 4" - 8"	150 psig 100 psig
Cast/ Ductile Iron		Styles 60 & 160	Bell-Joint Clamp	3" - 48"	100 psig
Steel, Cast/ Ductile Iron		Style 360	Full Circle Clamp	2" - 24"	Varies by size and application

# REPAIR & REINFORCING SLEEVES



PIPE	PRODUCT	STYLE NO.	CONFIGURATIONS	SIZES	PSI RATING
Cast/ Ductile Iron		Style 80 Sleeve	'Ready-Pack' Sleeve Repair of Cast/Ductile Iron Pipe	3" - 8"	150 psig
Cast/ Ductile Iron		Style 126 Sleeve	'Bell-Pack' Sleeve Repair of Cast Iron Bell & Spigot Joints	3" - 24"	100 psig



# REPAIR & REINFORCING SLEEVES (cont'd)

PIPE	PRODUCT	STYLE NO.	CONFIGURATIONS	SIZES	PSI RATING
Cast/ Ductile Iron		Style 50	Repair or Hot Tap of Cast/Ductile Iron	4" - 30" (and larger)	100 psig
Cast/ Ductile Iron		Style 50A Blackhawk	Hot Tap Sleeve w/Branch Outlet Options	4" - 30" Sleeve (Outlet by order)	100 psig
Steel  Cast/ Ductile Iron		Styles 54 & 73  Style 57	Repair of Steel Pipe  Repair of Cast/ Ductile Iron Pipe	2" - 4"  2" - 4"	500 psig  250 psig
Steel		Style 93	Low Profile Split Repair Sleeve for High Pressure Steel Pipe	6" - 20" (and larger)	500 psig
Steel		Style 96	Expanded Body Split Repair Sleeve for High Pressure Steel Pipe	6" - 20" (and larger)	500 psig
Steel		Style 97	Repair of High Pressure Steel Pipe <b>(Seal &amp; Restraint product when welded to pipe)</b>	3" - 48"	Up to ANSI 600 1440 psig
Steel		Style 110	Reinforcing Sleeve for Welded Joints <b>(Seal &amp; Restraint Product)</b>	4" - 30" (and larger)	Varies by size and application
Steel		Style 220	Reinforcing "Pumpkin" Sleeve for Coupled or Flanged Joints <b>(Seal &amp; Restraint Product)</b>	2" - 42"	Varies by size and application
Steel		Style 220S Small Diameter Sleeve	Reinforcing Sleeve for Threaded Collars, Welded Joints or Compression Couplings	3/4" - 2"	350 psig

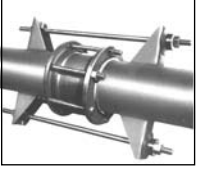
# REPAIR & REINFORCING SLEEVES (cont'd)

PIPE	PRODUCT	STYLE NO.	CONFIGURATIONS	SIZES	PSI RATING
Steel		Style 115 Style 315 PBR	Full-wrap Sleeves; Pressure-balanced Repair & Reinforcing Sleeves	Sized on Application	Varies by size and application
Steel to Steel		Style 440	Joint Harness for anchoring Steel to Steel pipe	2" - 38"	Restraint Only
Steel		Style 850	"Hot Line" Insulating Tapping Sleeve	2" - 6"	125 psig
Steel		<b>BLACKHAWK</b>	LS2 Fittings LineStop Fittings Hot Tap Sleeves	1-1/4" - 3" 2" - 48"	60 - 285 psig 150 Series to 285 psig 300 Series to 740 psig

# Meter Change-Out, M&R, and Transmission Sets

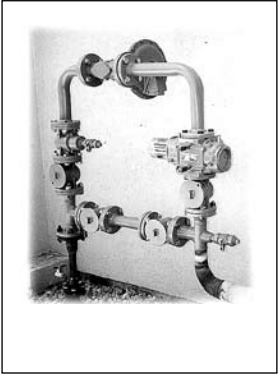
PRODUCT	STYLE NO.	CONFIGURATIONS	SIZES	PSI RATING
	Style 965	Meter Change-out Kits	Consult Factory per Application	Varies by Individual System Requirements
	Style 966  Custom-Built Gate Stations per Customer Specs	Prefabricated Meter Sets  Measurement & Regulation; Transmission & Distribution		



# DRESSER GAS PRODUCT WARNINGS

## PIPE PULLOUT

**! WARNING**

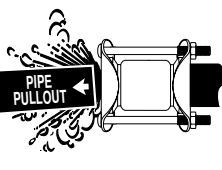

When pipe pullout could occur, pipe joint **MUST** be anchored. Failure to anchor pipe joint could result in escaping line content and cause property damage, serious injury or death.

Styles 38, 39, 39-62, 39-40, 40, 50, 54, 57, 63, 73, 75, 80, 88, 90, 93, 96, 97, 126, 128, 175, 275, 350, 360, 575 & 850.

## MARK & STAB DEPTH

**! WARNING**

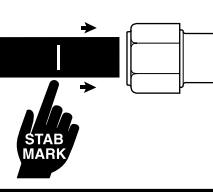

You **MUST** mark and stab the pipe into the fitting to the proper stab depth. Failure to do so could result in escaping line content that could cause property damage, serious injury or death.

Styles 38, 40, 50, 54, 57, 65, 73, 75, 80, 88, 90, 93, 96, 97, 126, 128, 175, 275, 350, 360, 401, 475, 501, 575, 700 & 711.

## INSERT STIFFENER

NOTE: On all polyethylene pipe ends, the recommended Dresser insert stiffener or an insert stiffener the user has qualified to meet CFR Title 49, DOT 192.283(b), must be installed.

**! WARNING**



Use proper insert in P.E. pipe end. Improper insert could result in escaping line content that could cause property damage, serious injury or death.

Styles 88, 90, 401, 475, 501, 575, 700 & 711.

## Style 501 TAP-N-VALVE Tees

**! WARNING**

On Weld Inlet Tees, remove tapping tool and all compression end components before welding. Failure to do so could destroy the gasket and result in escaping line content that could ignite and cause property damage, serious injury or death.

**! WARNING**

Ground Settlement or Pipe Bending Can Cause Plastic Line Breakage Over Time.

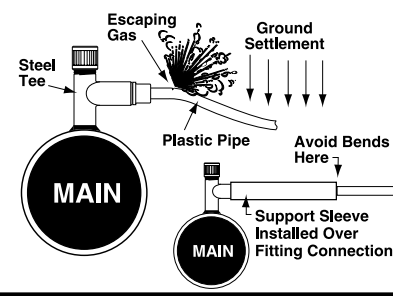

To limit shear and bending stresses at mechanical fitting connections, the use of a support sleeve is recommended to provide support from the effects of ground settlement. Bends at support sleeve exit should also be avoided. Failure to properly compact the soil and use a suitable support sleeve could result in escaping gas that could ignite and cause property damage, serious injury or death.

See Dresser Gas Products Installation Manual for more detailed Information.

## Style 501 Weld Adapters

**! WARNING**

On Weld Adapters, remove all compression end components before welding. Failure to do so could destroy the gasket and result in escaping line content that could ignite and cause property damage, serious injury or death.

## Dresser Couplings

**! WARNING**

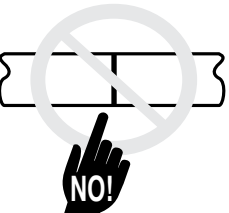

Do not butt pipe ends in the coupling. Butted pipe ends could result in escaping line content that could ignite and cause property damage, serious injury or death.

NEVER INSTALL ANY DRESSER® PRODUCT BEFORE READING THE INSTALLATION INSTRUCTIONS AND WARNINGS.

# SPECIAL PRODUCT WARNINGS

## Style 31 Line Caps

### **WARNING**

Do NOT remove tapping tools while Line Cap is under pressure. To do so could allow the Line Cap to blow off the line and cause serious injury or death. Also, escaping line content could ignite and cause serious injury, property damage or death.

## Style 480, 481 & 488 Excess Flow Valves

### **WARNINGS**

Proper selection of Excess Flow Valves is required. Improper selection can result in a condition that will not allow the device to operate, creating the potential for a dangerous condition if the line is severed.

Be certain of the proper orientation of the excess flow valve when installed in the service line. EFV devices installed backwards will not operate.

**ALWAYS READ ALL OF THE INSTALLATION / OPERATION INSTRUCTIONS, CAUTIONS AND WARNINGS WHEN SELECTING OR INSTALLING EXCESS FLOW VALVES! FAILURE TO FOLLOW THE ABOVE WARNINGS COULD RESULT IN IMPROPER OPERATION AND ESCAPING GAS THAT MAY CAUSE PROPERTY DAMAGE, SERIOUS INJURY OR DEATH!**

## Style 700 Universal POSI-HOLD®

### **WARNING**

**For Universal POSI-HOLD® Couplings Only:**

When P.E. pipe is used, the proper SDR Dresser insert **MUST** be used in each P. E. pipe end. Improper insert could result in escaping line content that could ignite and cause property damage, serious injury or death.

### **WARNING**

Proper selection of Excess Flow Valves is required. Also, proper orientation of the Excess Flow Valve when installed in the service line is critical.

Improper selection or installation of EFV's could create the potential for a dangerous condition if the line is severed. This condition could result in escaping line content that could cause property damage, serious injury or death!

## Style 700 Conductive & Insulating

### **WARNING**

P.E. pipe is **NOT** to be used in standard Conductive or Insulating POSI-HOLD® couplings. To do so could result in pipe pullout and escaping line content that could ignite and cause property damage, serious injury or death.

## NOTE:

**ALWAYS READ THE DRESSER INSTALLATION INSTRUCTIONS AND WARNINGS BEFORE INSTALLING ANY DRESSER PRODUCT!**

Visit us at: [www.dresser.com](http://www.dresser.com)

### **Piping Specialties | FloSystems | Blackhawk**

41 Fisher Avenue, Bradford, PA 16701

Phone: (814) 362-9200

Fax: (814) 362-9344

Email: [dmdsales@dresser.com](mailto:dmdsales@dresser.com)



Técnica Hansa - Marchant Pereira 540 Providencia  
Santiago, Chile. Teléfono: (+56 2) 2204 5348



[www.dresser.com](http://www.dresser.com)