



For drilled-end pipe

## Style 167 Lock Couplings

**Provides additional holding strength under unusual service conditions**

**Dresser Style 167 Lock Couplings** actually “lock” the pipe and the coupling together to protect the line from pipe separation due to unusual movement. These couplings are for exceptional conditions such as ash handling and coal transmission lines, or unanchored high-pressure surface lines where added holding strength is desired.

Style 167 lock couplings utilize standard Style 38 parts with the addition of leak-proof locking pins. The locking arrangement consists of threaded steel locking plugs at each end which extend through the middle ring into corresponding holes drilled in the pipe ends. This construction permits a “universal joint” action of the pipe in the coupling, yet prevents the pipe from pulling out under excessive longitudinal stresses.

### Style 167 Lock Couplings Specifications for Sizes 3” thru 12”

#### STYLE 167 FOR DRILLED-END STEEL PIPE

Nominal Size (In.)	Pipe O.D. (In.)	Middle Ring Length (In.)	Shipping Weight (lbs.)
3	3.500	10	17
3-1/2	4.000	10	19
4	4.500	10	21
4-1/2	5.000	10	22
5	5.562	10	25
	6.000	10	30
6	6.625	10	31
6	7.000	10	33
6	8.000	10	37
8	8.625	10	38
	10.000	10	46
10	10.750	10	51
12	12.750	10	58

#### STYLE 167 FOR DRILLED-END CIP

Nominal Size (In.)	Pipe O.D. (In.)	Middle Ring Length (In.)	Shipping Weight (lbs.)
3	3.800	10	19
3	3.960	10	19
4	4.800	10	24
4	5.000	10	24
6	6.900	10	31
6	7.100	10	33
8	9.050	10	39
8	9.300	10	42
10	11.100	10	64
10	11.400	10	65
12	13.200	10	88
12	13.500	10	90

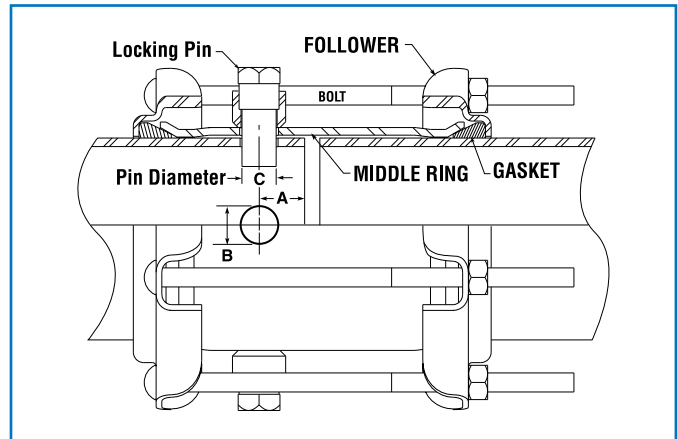

#### Style 167 Pipe-Drilling Table

Locking Pin		Drilling Dimensions	
Nominal Size	Lock Pin Diameter (C)	Distance from End of Pipe (A)	Drill Size (B)
1/2"	11/16"	15/16"	13/16"
3/4"	29/32"	1-1/4"	1-1/16"
1"	1-1/8"	1-7/16"	1-1/4"

#### Materials of Construction

**Followers:** AISI C1012 or ASME SA36  
**Middle Ring:** ASTM A513, ASTM A635 or ASME SA675 GR60  
**Bolts:** AWWA C 111/ANSI A21.11  
**Gaskets:** Grade 27 BUNA S  
**Coating:** Fusion-Bonded Epoxy Powder; Optional Shopcoat



Técnica Hansa - Marchant Pereira 540 Providencia  
 Santiago, Chile. Teléfono: (+56 2) 2204 5348